



MODEL USB-COM-2SM

USER MANUAL

FILE: USB-COM-2SM.A1b

Notice

The information in this document is provided for reference only. ADL Embedded Solutions Inc. does not assume any liability arising out of the application or use of the information or products described herein. This document may contain or reference information and products protected by copyrights or patents and does not convey any license under the patent rights of ADL Embedded Solutions Inc., nor the rights of others.

IBM PC, PC/XT, and PC/AT are registered trademarks of the International Business Machines Corporation.

Printed in USA. Copyright 2001, 2006 by ADL Embedded Solutions Inc., 4411 Morena Blvd. Suite 101, San Diego, CA 92117. All rights reserved.

WARNING!!

ALWAYS CONNECT AND DISCONNECT YOUR FIELD CABLING WITH THE COMPUTER POWER OFF. ALWAYS TURN COMPUTER POWER OFF BEFORE INSTALLING A CARD. CONNECTING AND DISCONNECTING CABLES, OR INSTALLING CARDS INTO A SYSTEM WITH THE COMPUTER OR FIELD POWER ON MAY CAUSE DAMAGE TO THE I/O CARD AND WILL VOID ALL WARRANTIES, IMPLIED OR EXPRESSED.

TABLE OF CONTENTS

Chapter 1: Introduction	4
Specifications	5
Figure 1-1: Block Diagram	7
Chapter 2: Installation	8
Hardware Installation	8
Chapter 3: Option Selection	9
Figure 3-1: Option Selection Map	10
Chapter 4: Address Selection	11
Chapter 5: Programming	12
Chapter 6: Connector Pin Assignments	13
Table 6-1: Serial Connector Pin Assignments	13
Appendix A: Application Considerations	14
Introduction.....	14
Table A-1: Connections Between Two RS422 Devices	14
Balanced Differential Signals	14-15
Table A-2: RS422 Specification Summary	15
RS485 Data Transmission.....	16
Figure A-1: Typical RS485 Two-Wire Network.....	16

Chapter 1: Introduction

This product is a USB interface device, incorporating a USB 4-port hub internally to provide two ports of Serial Communication in one product. The following paragraphs will first describe the Onboard Serial ports.

Serial Communication

This Serial Adapter was designed for effective multipoint transmission in any one of three modes on each channel. These modes are RS232, RS422 and RS485 (EIA485) protocol.

The board features two independent, asynchronous serial ports.

RS422 Balanced Mode Operation

The board supports RS422 communications and uses differential balanced drivers for long range and noise immunity. The board also has the capability to add load resistors to terminate the communications lines. RS422 communications requires that a transmitter supply a bias voltage to ensure a known "zero" state. Also, receiver inputs at each end of the network should be terminated to eliminate "ringing". The board supports biasing by default and supports termination by jumpers on the board. If your application requires the transmitter to be un-biased, please contact the factory.

RS485 Balanced Mode Operation

The board supports RS485 communications and uses differential balanced drivers for long range and noise immunity. RS485 operation involves switchable transceivers and the ability to support multiple devices on a single "party line". The RS485 specification defines a maximum of 32 devices on a single line. The number of devices served on a single line can be expanded by use of "repeaters".

This board also has the capability to add load resistors to terminate the communications lines. RS485 communications requires that one transmitter supply a bias voltage to ensure a known "zero" state when all transmitters are off. Also, receiver inputs at each end of the network should be terminated to eliminate "ringing". The board supports biasing by default and supports termination by jumpers on the board. If your application requires the transmitter to be un-biased, please contact the factory.

COM Port Compatibility

The FT232BM UARTs are used as Asynchronous Communication Elements (ACE). These include 128-byte transmit & 384-byte receive buffers to protect against lost data in multitasking operating systems, while maintaining 100 percent compatibility with the original IBM serial port. The system assigns the address(es).

A crystal oscillator is located on the board. This oscillator permits precise selection of baud rate up to 921.6K bps.

The driver/receiver used (SP491 in non-RS232 modes) is capable of driving extremely long communication lines at high baud rates. It can drive up to +60 mA on balanced lines and receive inputs as low as 200 mV differential signal superimposed on common mode noise of +12 V or -7 V. In case of communication conflict, the driver/receivers feature thermal shutdown.

The driver/receiver used in RS232 mode is the ICL3243.

Communication Mode

The board supports Half-Duplex communications with a 2-wire cable connection. Half-Duplex allows traffic to travel in both directions, but only one way at a time. RS485 communications commonly use the Half-Duplex mode since they share only a single pair of wires.

Baud Rate Ranges

The board has capability for baud rates up to 921.6K bps.

Serial Specifications

Communications Interface

- I/O Connection: Standard USB connector
- Serial Ports: 2 male D-sub 9-pin connectors
- Character length: 5, 6, 7, or 8 bits
- Parity: Even, odd or none
- Stop Interval: 1, 1.5, or 2 bits
- Serial Data Rates: Up to 921.6K
- Receiver Input Sensitivity: +200 mV, differential input
- Common Mode Rejection: +12V to -7V
- Transmitter Output Drive Capability: 60 mA, with thermal shutdown

Bus Type USB 1.1, USB 2.0 Host Compatible

Environmental

- Operating Temperature Range: 0°C to + 60°C
- Storage temperature Range: -50°C to +120°C
- Humidity: 5% to 95%, non-condensing
- Power Required:
 - 120mA maximum (see below)
 - Current: 0-60mA per COM channel
- Size: 4 inches wide by 4 inches deep by 1.75 inches high

USB Connector

The USB connector is a Type B connector and mates with the cable provided. The USB port provides communication signals along with +5 VDC power. The board is powered from the USB port or alternate USB connector.

A second USB Input Connector (P4) in parallel to the Type B connector is supplied. This second connector is a USB (OTG) connector.

Auxiliary USB Connector

This board has an optional feature. You can cable an extra USB type A connector to the onboard USB1.1 hub. This would provide an additional, "daisy-chained" USB 1.1 bus to which you can attach any 3rd party USB devices you may wish.

LED

There are three LEDs present on the product, functioning as follows:

Indicator	Function
1	USB Power Present
2	Serial Port 1 Activity
3	Serial Port 2 Activity

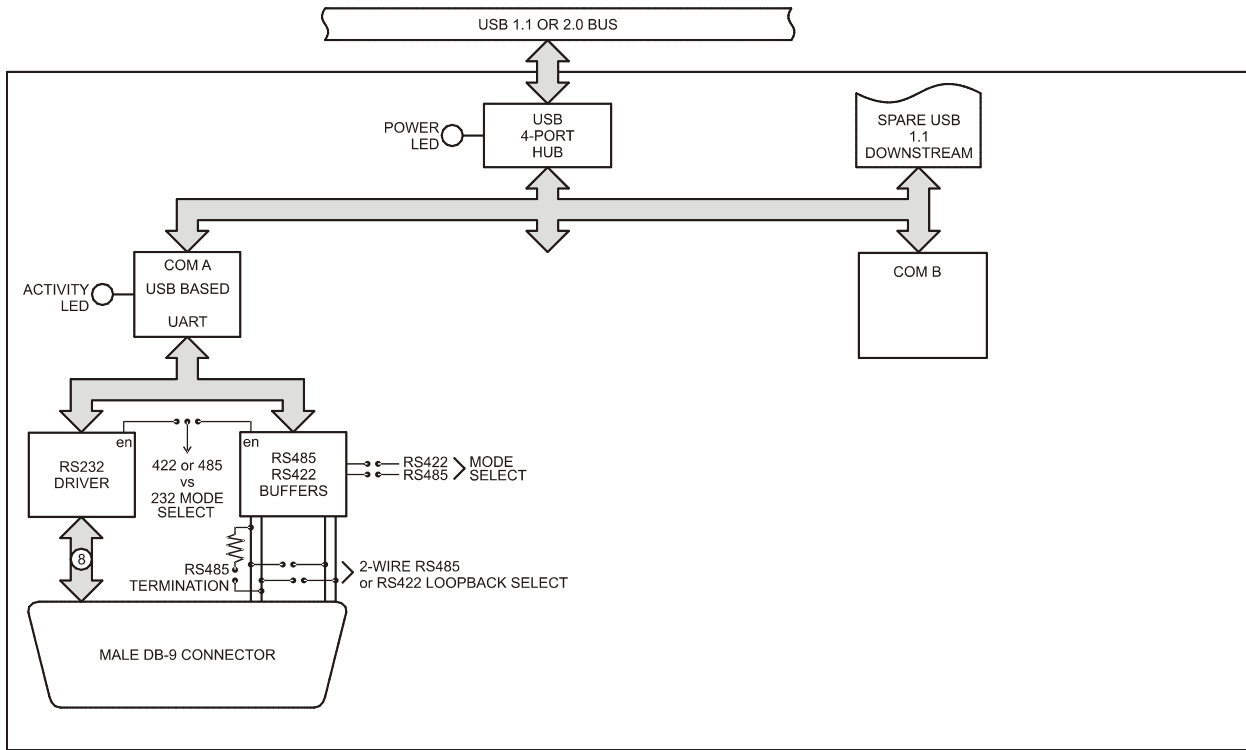

Figure 1-1:
Block
Diagram

Chapter 2: Installation

Software CD Installation

These paragraphs are intended to detail the software installation steps as well as describe what is being installed.

The software provided with this board is contained on one CD and must be installed onto your hard disk prior to use. To do this, perform the following steps as appropriate for your software format and operating system. Substitute the appropriate drive letter for your CD-ROM or disk drive where you see d: in the examples below.

WIN95/98/Me/NT/2000/XP/2003

- a. Place the CD into your CD-ROM drive.
- b. The CD should automatically run the install program. If the install program does not click START | RUN and type X .] b g h U ` ^ ` , click OK or press ? .
- c. Follow the on-screen prompts to install the software for this board.

LINUX

1. Please refer to linux.htm on the CD-ROM for information on installing under linux.

Hardware Installation

The unit can be connected to any USB 2.0 or USB 1.1 port. Please install the software package **before** plugging the hardware into the system.

Chapter 3: Option Selection

Refer to the setup programs on the CD provided with the board. Also, refer to the Block diagram and the Option Selection Map when reading this section of the manual.

Terminations

A transmission line should be terminated at the receiving end in its characteristic impedance. Installing a jumper at the locations labeled RS485-LD applies a 120Ω load across the transmit/receive input/output for RS485 operation.

Jumpers having to do with the termination of each channel are located near the output connector. They are labeled by channel. The load jumper is labeled "TERM". The other two jumpers are used to connect the transmit and receive lines for the two wire RS485 mode.

In RS485 operations where there are multiple terminals, only the RS485 ports at each end of the network should have terminating impedance as described above. To terminate the COM A port, place a jumper at the location labeled Ch A - RS485. To terminate the COM B port place jumpers at the location labeled Ch B - RS485.

Also, for RS485 operation, there must be a bias on the TRX+ and TRX- lines. If the adapter is not to provide that bias, consult the factory for technical support.

Data Cable Wiring

Signal	Pin Connection
Ain/out+	2
Ain/out-	3
100Ω to Ground	4

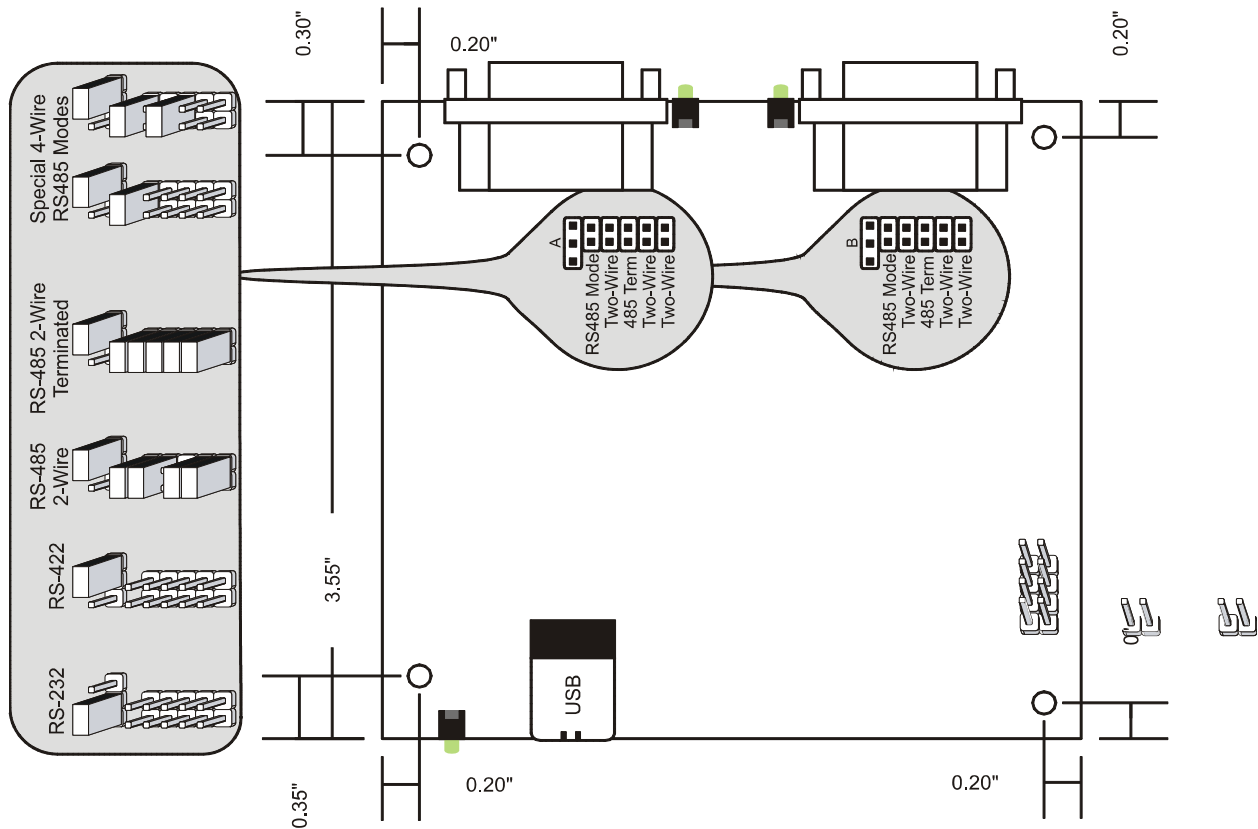

Figure 3-1: Option Selection Map

This board has 2 separate channels which can be individually configured. Each channel can be used in one of four modes:

- 1 RS232 - Install the top jumper in the RS232 position (left)
- 2 RS422 - Install the top jumper in the RS422/RS485 position (right)
- 3 RS485 (4 wire) - Install the top jumper in the RS422/RS485 position (right) and the RS485 Mode jumper
- 4 RS485 (2 wire) - Install the top jumper in the RS422/RS485 position (right), the RS485 Mode jumper, the RS485 TxRx+ jumper and the RS485 TxRx- jumper.

To provide a termination load in the RS485 mode, install the appropriate RS485 TERM jumper.

The jumpers on the board must be properly placed in order to have the board function properly.

Note: Any unneeded jumpers that are installed can cause the adapter to function incorrectly.

Chapter 4: Address Selection

Use the provided driver to access the USB board. This driver will allow you to determine how many supported USB devices are currently installed, and each device's type. This information is returned as a Vendor ID (VID), Product ID (PID) and Device Index.

The board's VID is "0x1605", and its PID is "0x8030".

The Device Index is determined by how many of the device you have in your system, and provides a unique identifier allowing you to access a specific board at will.

Chapter 5: Programming

Sample Programs

There are sample programs provided with the board in C, Pascal, QuickBASIC, and several Windows languages. DOS samples are located in the DOS directory and Windows samples are located in the WIN32 directory.

Windows Programming

The board installs into Windows as COM ports. Thus the Windows standard API functions can be used. In particular:

- < CreateFile() and CloseHandle() for opening and closing a port.
- < SetupComm(), SetCommTimeouts(), GetCommState(), and SetCommState() to set and change a port's settings.
- < ReadFile() and WriteFile() for accessing a port.

See the documentation for your chosen language for details.

Under DOS, the process is identical to programming any 16550- or 16750-compatible UART.

Address Map

The core of the UART function is supplied by the FTDI FT232BM chip.

Chapter 6: Connector Pin Assignments

DB-9 Male Pin for each of Ch A-G	RS-232 Signals (Industry Standard)	RS-485 Signals (2 Wire)	RS-422 Signals (Also 4wire RS485)
Ch x - 1	DCD	RX-/TX-	RX-
Ch x - 2	RX	TX+/RX+	TX+
Ch x - 3	TX	TX-/RX-	TX-
Ch x - 4	DTR		
Ch x - 5	Gnd	Gnd	Gnd
Ch x - 6	DSR		
Ch x - 7	RTS		
Ch x - 8	CTS		
Ch x - 9	RI	RX+/TX+	RX+

Table 6-1: Serial Connector Pin Assignments

Appendix A: Application Considerations

Introduction

Working with RS422 and RS485 devices is not much different from working with standard RS232 serial devices and these two standards overcome deficiencies in the RS232 standard. First, the cable length between two RS232 devices must be short; less than 50 feet at 9600 baud. Second, many RS232 errors are the result of noise induced on the cables. The RS422 standard permits cable lengths up to 5000 feet and, because it operates in the differential mode, it is more immune to induced noise.

Connections between two RS422 devices (with CTS ignored) should be as follows:

Device #1		Device #2	
Signal	Pin No.	Signal	Pin No.
Gnd	5	Gnd	5
TX ⁺	2	RX ⁺	9
TX ⁻	3	RX ⁻	1
RX ⁺	9	TX ⁺	2
RX ⁻	1	TX ⁻	3

Table A-1: Connections Between Two RS422 Devices

A third deficiency of RS232 is that more than two devices cannot share the same cable. This is also true for RS422 but RS485 offers all the benefits of RS422 plus allows up to 32 devices to share the same twisted pairs. An exception to the foregoing is that multiple RS422 devices can share a single cable if only one will talk and the others will all receive.

Balanced Differential Signals

The reason that RS422 and RS485 devices can drive longer lines with more noise immunity than RS232 devices is that a balanced differential drive method is used. In a balanced differential system, the voltage produced by the driver appears across a pair of wires. A balanced line driver will produce a differential voltage from ± 2 to ± 6 volts across its output terminals. A balanced line driver can also have an input "enable" signal that connects the driver to its output terminals. If the "enable signal is OFF, the driver is disconnected from the transmission line. This disconnected or disabled condition is usually referred to as the "tristate" condition and represents a high impedance. RS485 drivers must have this control capability. RS422 drivers may have this control but it is not always required.

A balanced differential line receiver senses the voltage state of the transmission line across the two signal input lines. If the differential input voltage is greater than +200 mV, the receiver will provide a specific logic state on its output. If the differential voltage input is less than -200 mV, the receiver will provide the opposite logic state on its output. A maximum operating voltage range is from +6V to -6V allows for voltage attenuation that can occur on long transmission cables.

A maximum common mode voltage rating of $\pm 7V$ provides good noise immunity from voltages induced on the twisted pair lines. The signal ground line connection is necessary in order to keep the common mode voltage within that range. The circuit may operate without the ground connection but may not be reliable.

Parameter	Conditions	Min.	Max.
Driver Output Voltage (unloaded)		4V	6V
		-4V	-6V
Driver Output Voltage (loaded)	LD and LDGND	2V	
	jumpers in	-2V	
Driver Output Resistance			50 Ω
Driver Output Short-Circuit Current			± 150 mA
Driver Output Rise Time			10% unit interval
Receiver Sensitivity			± 200 mV
Receiver Common Mode Voltage Range			$\pm 7V$
Receiver Input Resistance			4K Ω

Table A-2: RS422 Specification Summary

To prevent signal reflections in the cable and to improve noise rejection in both the RS422 and RS485 mode, the receiver end of the cable should be terminated with a resistance equal to the characteristic impedance of the cable. (An exception to this is the case where the line is driven by an RS422 driver that is never "tristated" or disconnected from the line. In this case, the driver provides a low internal impedance that terminates the line at that end).

Note

You do not have to add a terminator resistor to your cables when you use the adapter. Termination resistors for the RX+ and RX- lines are provided on the board and are placed in the circuit when you install the Ch X - LD jumpers.

RS485 Data Transmission

The RS485 Standard allows a balanced transmission line to be shared in a party-line mode. As many as 32 driver/receiver pairs can share a two-wire party line network. Many characteristics of the drivers and receivers are the same as in the RS422 Standard. One difference is that the common mode voltage limit is extended and is +12V to -7V. Since any driver can be disconnected (or tristated) from the line, it must withstand this common mode voltage range while in the tristate condition.

The following illustration shows a typical multidrop or party line network. Note that the transmission line is terminated on both ends of the line but not at drop points in the middle of the line.

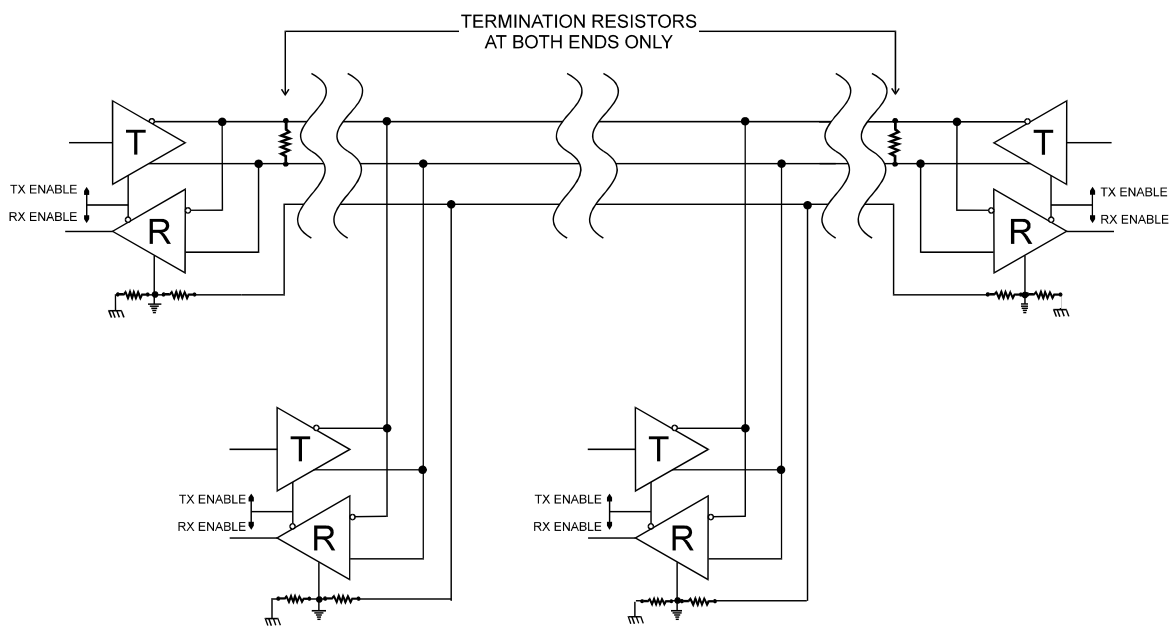

Figure A-1:
Typical RS485 Two-Wire Multidrop Network

RS485 Four-Wire Multidrop Network
An

RS485 network can also be connected in a four-wire mode. In a four-wire network it's necessary that one node be a master node and all others be slaves. The network is connected so that the master communicates to all slaves and all slaves communicate only with the master. This has advantages in equipment that uses mixed protocol communications. Since the slave nodes never listen to another slave's response to the master, a slave node cannot reply incorrectly.

Customer Comments

If you experience any problems with this manual or just want to give us some feedback, please email us at: sales@adl-usa.com. Please detail any errors you find and include your mailing address so that we can send you any manual updates.



ADL Embedded Solutions GmbH, Eiserfelder Straße 316 D-57080 Siegen,
Germany P. +49 (0) 271 250 810 0 F. +49 (0) 271 250 810 20
e-mail: sales@adl-europe.com; web: www.adl-europe.com

ADL Embedded Solutions Inc., 4411 Morena Blvd., Suite 101
San Diego, CA 92117-4345 P. +1 858 490-0597 F. +1 858 490-0599
e-mail: sales@adl-usa.com; web: www.adl-usa.com

