



USB-COM-2SM - Two Port USB to Serial Communication Module

FEATURES

- Dual-port serial adapter for USB 1.1 and USB 2.0 host ports
- Two serial ports, field selectable RS-232/422/485
- All required power drawn from USB port, no external power adapter required
- Extra downstream USB expansion port
- PC/104 module size and mounting compatibility
- Small (4"x 4"x 1.8") rugged industrial enclosure

FACTORY OPTIONS

- DIN rail mounting provision
- OEM (board only) version with PC/104 mounting holes and PCB footprint for added flexibility in embedded applications

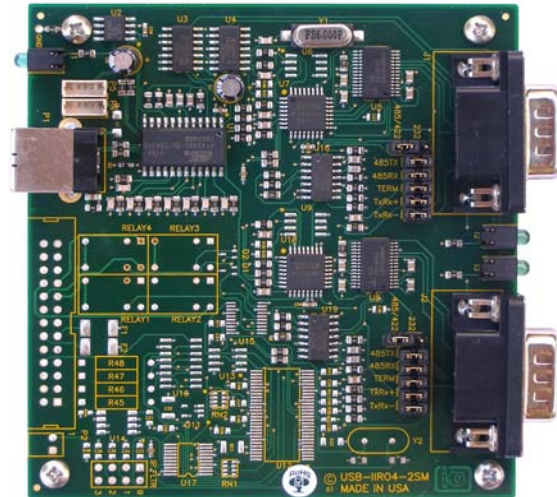

FUNCTIONAL DESCRIPTION

The USB-COM-2SM is a two-port asynchronous serial communication adapter designed for use with any computer system equipped with a USB port. Multiple peripherals such as POS, barcode scanners, scales, date-entry terminals, data acquisition modules, and automation equipment can now be recognized and used on a single USB port. Simply install the included software and connect the unit to your USB port. It instantly provides two RS-232, RS-422, or RS-485 serial ports which can be selected on a port by port basis. It is now easier than ever to add serial ports and serial devices to any application along with easy plug-and-play and hot-swapping features. The unit enclosure is 4 inches wide by 4 inches deep by 1.8 inches high. The adapter is supplied with a 6 foot USB cable and has two male DB9 connectors with jack-screws for secure cable connections. The DB9 connectors are conveniently located at the front of the unit and feature easy-to-read LEDs indicating serial port activity. The USB connector is located at the back of the unit and also features a LED for USB status. The USB-COM-2SM is fully compatible with both USB 1.1 and USB 2.0 ports. The OEM (board only) version provides just the board without the enclosure and is ideal for a variety of embedded OEM applications. An additional USB input header is provided on the board for OEMs along with a downstream USB port for connecting additional USB devices.

SERIAL

Type FT232 UARTs are used as asynchronous communication elements. This includes 384-byte receive / 128-byte transmit FIFO buffers for high data throughput and to protect against lost data in multitasking systems. Crystal oscillators located on the card permit precise baud rate capability up to 230.4K for use in RS-232 mode, using ICL3243 type drivers. Speeds up to 921.6K are achievable using RS-422 & RS-485. The driver/receivers used are type SP491 which are capable of driving long communication lines at high baud rates. They can drive up to ± 60 mA on balanced lines and receive inputs as low as 200 mV differential signal superimposed on common mode noise of +12V to -7V. In case of communication conflict, the driver/receivers feature thermal shutdown.

OEM USB/104 FORM FACTOR

What makes the OEM option unique is that its PCB size and mounting holes match the PC/104 form factor (without the bus connections). This allows our rugged digital/serial board to be added to any PCI-104 or PC/104 stack by connecting it to a simple USB port usually included on-board with embedded CPU form factors such as EBX, EPIC, and PC/104 - especially important since many newer CPU chipsets do not support ISA and have plenty of USB ports. Future stacks will be using the extremely fast PCI Express bus which is essentially overkill for simple digital monitoring and control. The USB-COM-2SM OEM board can also be added into many pre-existing standard PC/104 based systems and enclosures.

ACCESSORIES

The USB-COM-2SM is available with optional DIN rail mounting provision.

SOFTWARE

The USB-COM-2SM is plug-and-play which allows quick connect or disconnect whenever you need additional serial ports through your USB port. The USB-COM-2SM is supported for use in most USB supported operating systems and includes a free Linux and Windows 98se/Me/2000/XP/2003 compatible software package. This package contains sample programs and source code in Visual Basic, Delphi, C++ Builder, and Visual C++ for Windows. Also incorporated is a graphical setup program in Windows. Third party support includes a Windows standard DLL interface usable from the most popular application programs. Embedded OS support include Windows Xpe. For serial communications the package includes an easy to use terminal program for testing out your COM ports. Use in other operating systems may also be supported, contact Factory.



BLOCK DIAGRAM

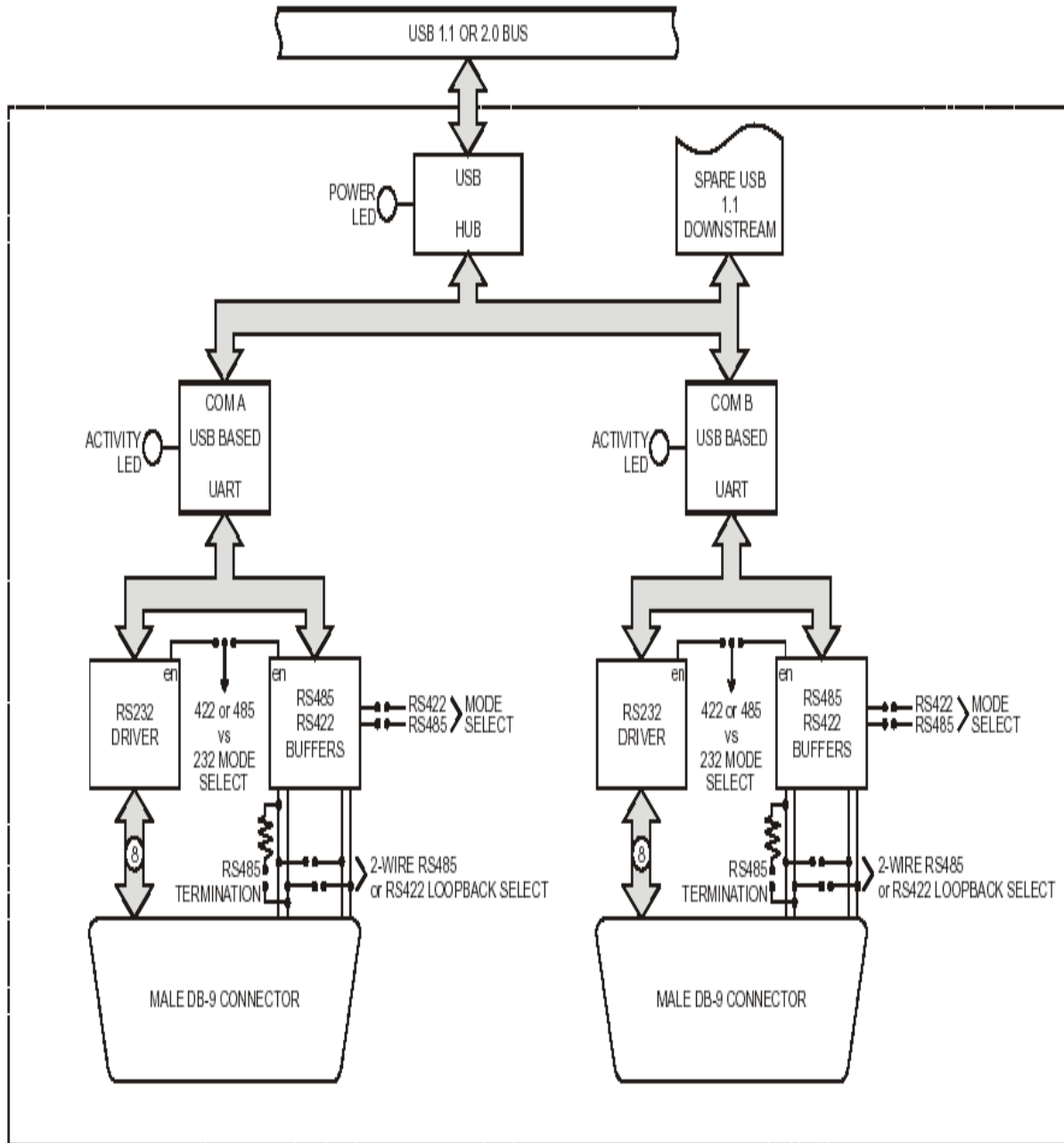



SPECIFICATIONS

Communications Interface

I/O Connections:	All RS-232 signals are supported and present at the DB9 connectors RS-422 Data Signals: Tx+, Tx-, Rx+, Rx-, GND RS-485 Data Signals: 2-wire: Tx/Rx+, Tx/Rx-, GND 4-wire: Tx+, Tx-, Rx+, Rx-, GND Jumper selectable termination
Serial Data Rates:	Up to 230.4K bps, asynchronous for RS-232 Up to 921.6K bps, asynchronous for RS-422 and RS-485
Multidrop:	Compatible with RS-485 specifications - Up to 32 drivers and receivers allowed on line. Driver / Receiver type SP491.
Character Length / Parity / Stop Interval:	5, 6, 7 or 8 data bits / Even, odd or no parity / 1, 1.5 or 2 Stop Bits
Receiver Sensitivity:	±200 mV differential input
Common Mode Voltage:	+12V to -7V
Transmitter Output Drive:	6- mA with thermal shutdown
Termination:	Jumper selectable per channel for RS-485 mode
Bias:	On-board from factory on transmit lines for RS-422 and RS-485

Bus Type USB 1.1 Full-speed, USB 2.0 High-speed compatible

Environmental

Operating Temperature Range:	0° to +60° C
Storage Temperature Range:	-50° to +120° C
Humidity:	5% to 95% RH, non-condensing
Board Dimensions:	3.550 x 3.775 inches.
Box Dimensions:	3.780 x 4.170 x 1.800 inches high.

Power

+5VDC provided via USB bus up to 500mA
5V@ 120mA maximum
0-60mA for each COM channel

Ordering Guide

USM-COM-2SM Enclosure and module with 2 port USB to RS-232/422/485 serial

Options

-OEM	Board only (No Enclosure)
-DIN	Din Rail Mounting Kit

Accessories

ADAP9 DB9 connector external-mounted screw termination board