

TKS-G50-QM77

EmBox with Intel® 3rd Generation Core™ i7/i5/i3 Mobile Processor

Front View



Rear View



Specifications

System		
CPU	Intel® Core™ i7/i5/i3/Celeron® PGA processor support Intel® Core™ i7-3610QE 2.3 GHz, Intel® Core™ i5-3610ME 2.7GHz, Intel® Core™ i3-3120ME 2.4GHz	
Chipset	Intel® QM77/HM76	
System Memory	204-pin DDR3 SODIMM x 1, Max. 8 GB	
Display Interface	VGA	DB-15 x 1
	DVI	Optional
	HDMI	—
	Others	—
Storage Device	SSD	2.5" SSD x 1 (optional)
	HDD	2.5" SATA HDD bay x 1
Network	LAN	Gigabit Ethernet
	Wireless	Optional by Mini Card

Features

- Intel® 3rd Generation Core™ i7/i5/i3 Mobile Processor
- Intel® QM77/HM76
- SODIMM DDR3 1066/1333/1600, Max. 8 GB
- Gigabit Ethernet x 2
- CRT, DVI (Optional)
- SATA 6.0Gb/s x 2, CFAST™ x 1
- USB3.0 x 2, USB2.0 x 2, COM x 4, 8-bit Digital I/O
- Mini Card x 1
- Supports Hi-Safe and Hi-Manager (iAMT)*



Front I/O	USB Host	USB 2.0 x 2
	LAN	—
	Serial Port	RS-232 x 1
	DIO	—
	Audio	Mic-in, Line-out
	KB/MS	—
Others	Power & HDD indicated LED x 2, antenna hole x 2	
Rear I/O	USB Host	USB 3.0 x 2
	LAN	RJ-45 x 2
	Serial Port	RS-232 x 3 (COM2: RS-232/ 422/ 485)
	DIO	8-bit
	Audio	—
	KB/MS	—
Others	Power On/Off Switch x 1, Power DC-in, VGA x 1	
Expansion	PCIe	—
	PCI	—
	Mini Card	1
	Mini PCI	—
Others	CFAST™ x 1	
Indicator	Front	Power LED x 1, Hard Disk Drive active LED x 1
	Rear	—
Power Requirement	DC-in +12V ATX with DC jack, lockable	
Power Consumption	Intel® Core™ i7-3610QE 2.3 GH DDR3 1333 8G: 5.2A@+12V Intel® Core™ i7-3610ME 2.7 GH DDR3 1333 8G: 3.47A@+12V	
System Cooling	Fan (support easy fan)	
Mechanical		
Mounting	Wallmount (optional)	
Dimension	7.79" x 7.09" x 1.77" (198mm x 180mm x 45mm)	
Gross Weight	3.75 lb (1.7 Kg)	
Net Weight	2.87 lb (1.3 Kg)	
Certification	EMC	CE/ FCC Class A
	Safety	—
Environmental		
Operation Temperature	32°F ~ 122°F (0°C ~ 50°C)	
Storage Temperature	-40 °F ~ 176 °F (-40 °C ~ 80 °C)	
Operation Humidity	0% ~ 95% relative humidity, non-condensing	
Anti-Vibration	1g rms / 5 ~ 500Hz / operation – HDD	
Anti-Shock	20g peak acceleration (11 msec. duration) – HDD	
MTBF	50,000 Hours (not include Power adapter)	
OS support	Windows® XP Embedded, Windows® XP, Windows® 7, Linux Fedora	
Others	Supports Hi-Safe, Hi-Manager	

TKS-G50-QM77

Dimension

Unit: mm

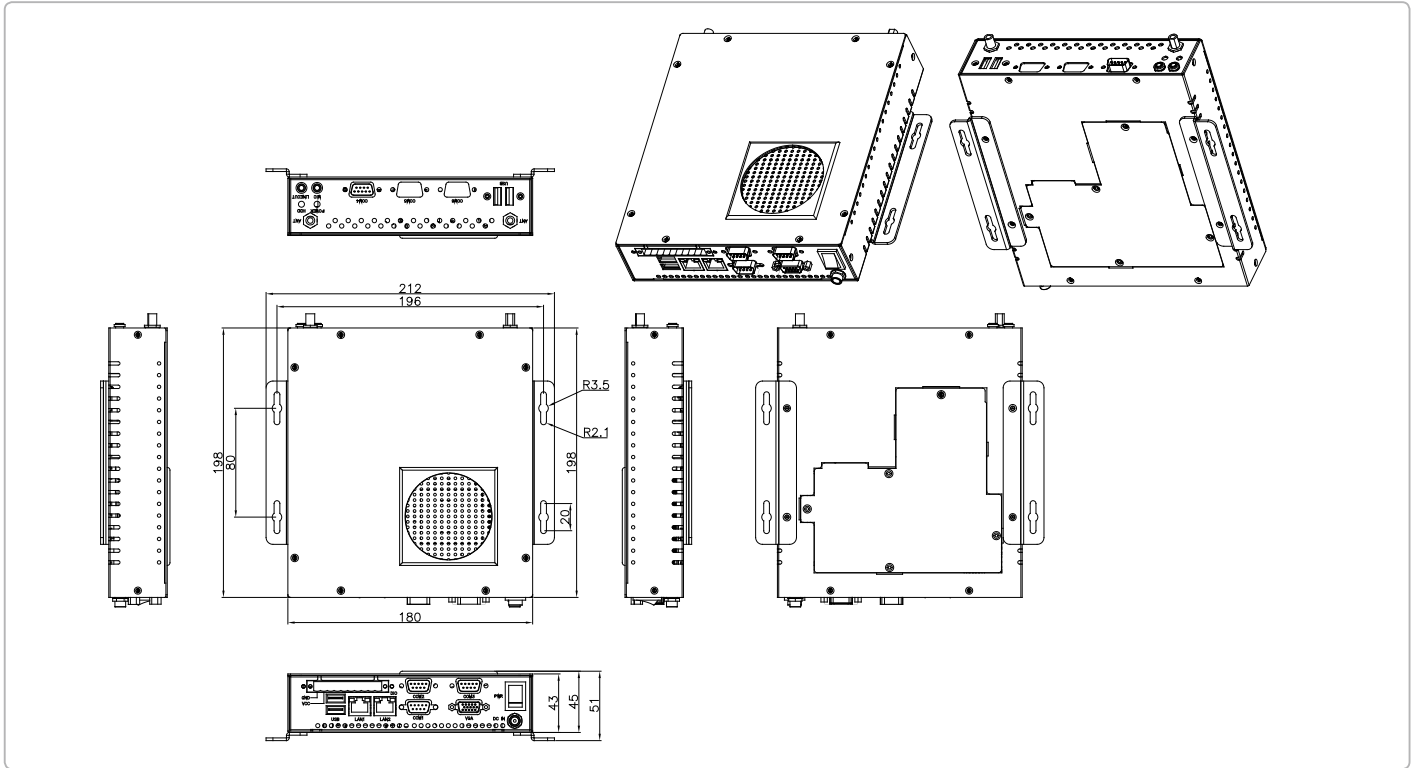

Packing List

- CPU Cooler With Fan
- Product CD
- TKS-G50-QM77

Optional Accessories

- 1702031802
Power Cord (US Type)
- 1702031803
Power Cord (European Type)
- 170203180E
Power Cord (Japanese Type)
- M04CV05030
Wallmount kit x 2
- 84W AC Adapter
- 120W AC adapter

Ordering Information

Part Number	CPU	RAM	Cooler	Storage	Display	LAN	USB	RS-232	RS-232/422/485	Expansion Slot	Power
TKS-G50-QM77-001-DX	Intel® 3rd Gen. Core™ i7/i5/i3 PGA CPU	DDR3	Fan	2.5" SATA	CRT	2	USB2.0 x 2	2	1	Mini Card x1	+12VDC/ ATX