



Features

- Onboard Intel® Atom™ N270 1.6 GHz Processor
- 8.4" SVGA Color TFT LCD
- High Brightness Display-800 Nits (Optional)
- Backlight ON/OFF & Brightness Adjustment
- Supports Wireless LAN With Dual External Antennas (Optional)
- Water-Proof I/O Connector (IP-65 Rating)



Specifications

System	
Processor	Intel® Atom™ N270 1.6 GHz Processor
System Memory	DDR SODIMM x 1, Max. 2 GB
LCD/CRT Controller	Intel® 945GSE
Ethernet	GbE LAN, RJ-45 x 1
I/O Port	RS-232 x 1, RS-232/422/485 x 1, USB2.0 x 2, GbE LAN, RJ-45 x 1 (optional)
Storage Disk	SATA DOM, Max. 8GB
Expansion Slot	Mini PCI slot x 1 (internal)
OS Support	Windows® XP Pro, Windows® XP Embedded, Windows® 7
Mechanical	
Construction	Sealed Aluminum Alloy Chassis
Color	Silver Gray
Mounting	VESA 75mm
Dimension	10.5" x 7.6" x 2.4" (266mm x 192mm x 59.8mm)
Carton Dimension	13.86" x 12.91" x 7.72" (352mm x 328mm x 196mm)
Gross Weight	8.8 lb (4 kg)
Net Weight	6.6 lb (3 kg)
Environmental	
Operating Temperature	-4°F ~ 131°F (-20°C ~ 55°C) (with external heat sink)
Storage Temperature	-4°F ~ 140°F (-20°C ~ 60°C)
Storage Humidity	10 to 90% @ 400C, non-condensing
Vibration	3G Random Operation, 5~500Hz
Shock	30G peak acceleration (11 msec. duration)/ operation
Safety	All sides of IP-67 Certificated
EMC	CE/FCC Class A
Power Supply	
DC-DC Input, 90W	Input Range: 9V ~ 30V DC
LCD	
Display Type	8.4" TFT-LCD
Max. Resolution	800 x 600
Max. Color	262K colors
Dot Size	0.213 x 0.213
Luminance (Typical)	450 nits
View Angle	150°(H)/150°(V)
Back Light MTBF (Hours)	50,000
Touchscreen	
Type	4-wire, Analog Resistive
Resolution	2048 x 2048
Light Transmission	> 78% (FOX-81HTT)
Lifetime	1 million activations

FOX-81

Dimension

Unit: mm

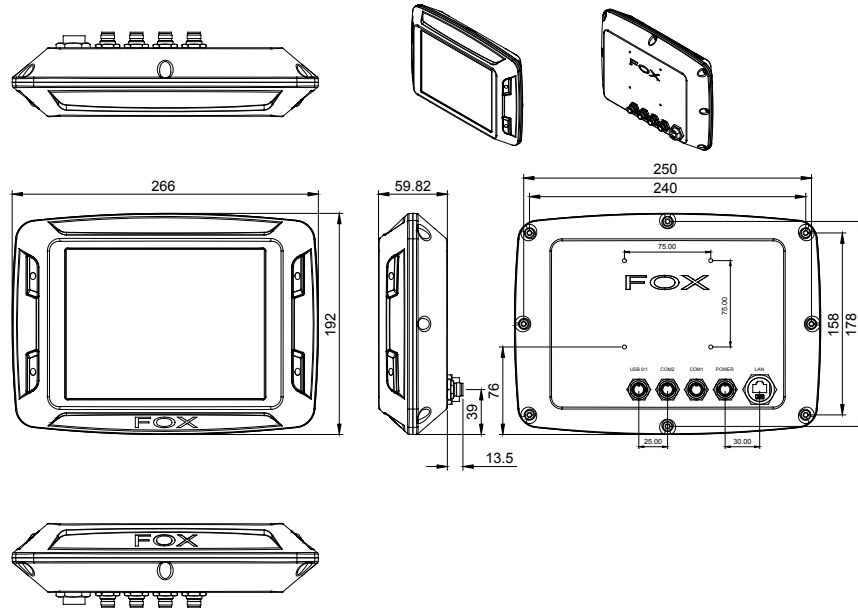

Ordering Information

- **TF-FOX- 81HTT-A1**
Intel® Atom™ N270 1.6 GHz MPWP Panel PC with 8.4" LCD, 512 MB RAM, GbE LAN, Touch Screen, XPE on 2 GB SATA DOM
- **TF-FOX- 81HTT-A2**
Intel® Atom™ N270 1.6 GHz MPWP Panel PC with 8.4" LCD, 512 MB RAM, Line out, Touch Screen, XPE on 2GB SATA DOM, 1 Antenna

Accessories in Packing

- **1700090208**
COM (D-SUB) Cable with Waterproof M12 Connector (30cm) (FOX series)
- **1709080251**
Two USB Y Cables with Waterproof M12 Connector (30cm) (FOX series)
- **M990FOX001**
3-pin Water-proof Cap Connector for DC-in or Audio Line-out Port (FOX series)
- **P990FOX001**
Water-proof Cap Connector for LAN Port of FOX series (RJ-45 compliance)

Optional Accessories

- **1757910004**
AC Adapter (100W)
- **1702031802**
AC adapter Power Cord (US type)
- **1702031803**
AC Adapter Power Cord (European type)
- **170203180E**
AC Adapter Power Cord (Japanese type)
- **968C409666**
High Profile 4G SATA DOM
- **968C81923E**
High Profile 8G SATA DOM
- **9761F1R101**
WiFi Kit, 802.11 b/g