



### 104-COM232-8 / 104-COM232-4 / 104-COM232-2



#### KEY FEATURES:

- 8, 4 or 2 RS-232 asynchronous serial COM ports
- Speeds up to 921.6K with 64-byte FIFO
- Programmable IRQ sharing simplifies system design and installation
- Low power required: +5VDC at 80mA typical
- Operates as a standard COM port in all operating systems

#### FACTORY OPTIONS:

- 0 to 70°C and -40 to +85°C versions available
- 128-byte FIFO

The 104-COM232-8 series are eight, four, or two-port asynchronous, RS-232 serial communication boards. The boards are feature-rich and allow for the connection of multiple serial devices—ideal for a variety of applications such as POS, barcode readers, modems, machine monitoring and control, military, high-density networking applications or any other application requiring the connection of RS-232 serial devices to a PC/104 compatible system.

Ports are accessed via two 40-pin IDC type right angle header connectors for the boards optional breakout cable.

The 104-COM232-8 series were designed using type 16780 UARTS and include 64-byte transmit/receive FIFO buffers to protect against lost data in multi-tasking systems while maintaining 100% compatibility with all operating system COM port drivers. ADL offers the 104-COM232-8 series in both standard and extended temperature versions ideal for outdoor applications or harsh industrial surroundings.

Ordering options include UARTs with larger FIFOs, support for custom baud rates, vertical I/O pins, and custom cabling.

#### SOFTWARE

The 104-COM232-8 series are supported for use in all operating systems and include a free DOS, Linux and Windows 95/98/Me/NT/2000/XP/2003 compatible software package. This includes sample programs and source code in "C" and Pascal for DOS, and Visual Basic, Delphi, C++ Builder, and Visual C++ for Windows. Also included is a graphical setup program in Windows. Embedded OS support includes Windows XPe and CE. An easy-to-use Windows terminal program simplifies verification of proper operation.

Data subject to change without notice.



### 104-COM232-8 / 104-COM232-4 / 104-COM232-2

#### Block Diagram & Pin Configuration

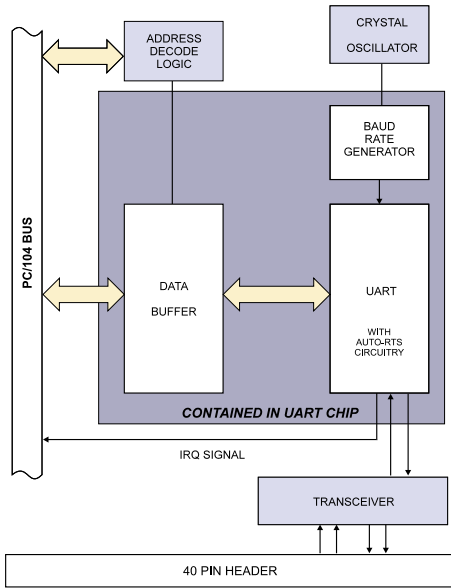

#### Specifications

##### Serial Ports

Number of serial ports	8, 4, or 2
Protocol	Full RS-232
Maximum baud rate	921.6K
Character length	5, 6, 7, or 8 data bits
Parity	Even, odd, or none
Common mode voltage range	+12V to -7V
Base address options	Programmable
Interrupts	Shared IRQ is programmed and stored onboard in non-volatile memory

##### General

I/O connections	Via two 40 pin IDC type right angle connectors. There are eight pins per port plus common grounds.
Short circuit protection	All outputs protected against continuous short circuit
Power required	+5VDC at 80mA typical, all outputs open
Operating temperature	-40 to +85°C optional, all versions
Operating humidity	5% to 95% RH, non-condensing
PC/104 bus	8-bit and 16-bit bus headers are used

#### Ordering Guide

104-COM232-8	8-port RS-232
104-COM232-4	4-port RS-232
104-COM232-2	2-port RS-232

Data subject to change without notice.